

CBM-650

(COMB MANUAL BINDING MACHINE)

OPERATIONAL MANUAL

INTRODUCTION

CONGRATULATIONS ON THE PURCHASE OF YOUR NEW **CBM-650**, A PROFESSIONAL AND HEAVY-DUTY COMB BINDING MODULE. YOUR **CBM-650** WAS DESIGNED WITH A FULL RANGE OF FUNCTION AND PREMIUM QUALITY COMPONENTS TO GUARANTEE YOU AN EFFORTLESS AND PROFESSIONAL BIND AS WELL AS MANY YEARS OF TROUBLE-FREE SERVICE.

IMPORTANT

WE RECOMMEND THAT YOU TAKE A FEW MINUTES TO FAMILIARIZE YOURSELF WITH THE FUNCTIONS OF YOUR NEW **CBM-650**. YOU WILL FIND THAT WITH JUST A LITTLE PRACTICE, ANY PERSON CAN ACHIEVE PROFESSIONAL RESULTS.

FEATURES

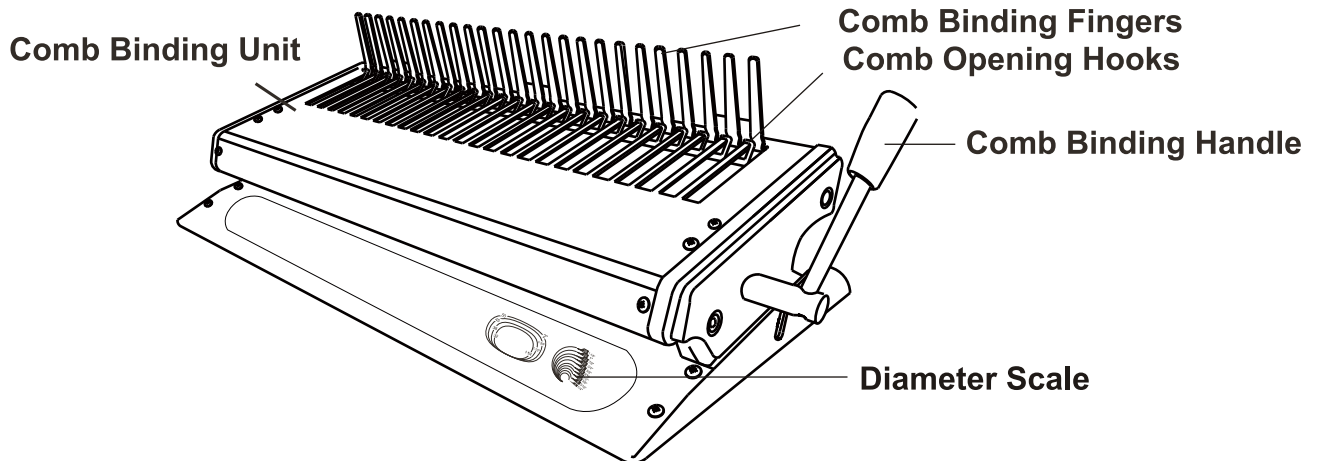

ASSEMBLY & SAFETY INSTRUCTION

1. Place your new **CBM-650** on top of a sturdy working table. **See picture 1.**
2. Place Comb Binding unit on top of **CBM-650** and fasten it by attached screws & wrench. **See picture 2.**
3. 把手左右邊通用 **See picture 3.**

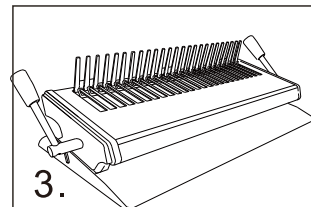
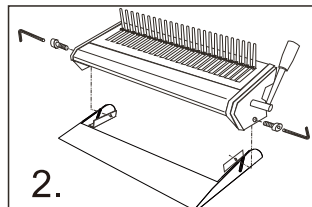
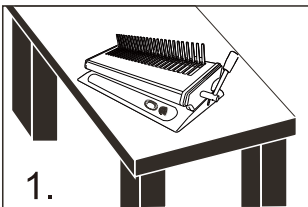

COMB BINDING

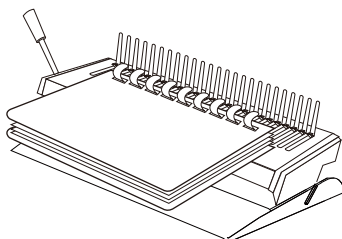

1. Use Master Selector to select / identify the size of your wires or combs. **See picture 1.**
2. Place pre-selected comb behind Comb Binding Fingers. The comb opening side should be upward. **See picture 2.**

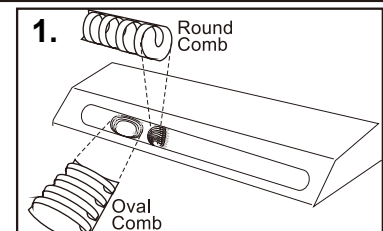

3. Slowly pull Comb Binding Handle forward to open comb until the comb binder is opened sufficiently to allow pages and covers to be inserted. **See picture 3.**

4. Neatly align the pages and covers. Holding the documents tightly with the front towards you, feed the comb through the holes. **See picture 4.**

5. When all comb are fully positioned through the holes, slowly move handle backward to close the comb. Lift out the bound documents from fingers. The comb binding is complete. **See picture 5.**

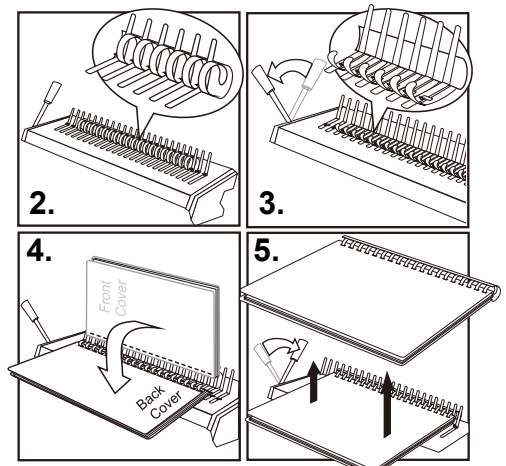

INSTALL COMB BINDING

CBM-650 (Install Comb Binding)unit to machine as illustrated.

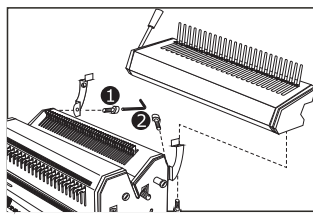

DUOMAC

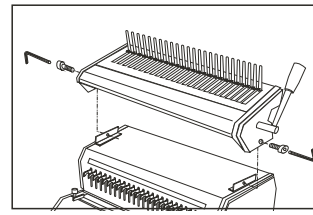
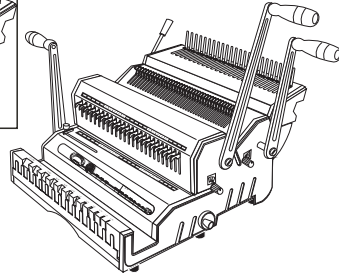

COMB-240E

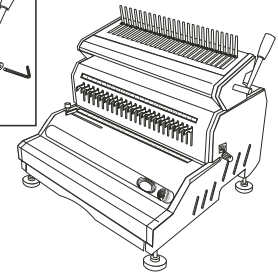

TECHNICAL INFORMATION

Size	Comb 9/16" (14.28mm)					
	■	■	■	■	■	■
Punching Length	14"	=	24 Holes			
	LEGAL	=	23 Holes			
	A4	=	21 Holes			
	11"	=	19 Holes			
	8.5"	=	15 Holes			
	A5	=	14 Holes			
Binding Capacity	<u>Sheets</u> 70-80 g/m ²		<u>Diameters</u> Inch mm			
	ROUND COMB					
	30	1/4	6	190	7/8	22
	50	5/16	8	220	1	25
	60	3/8	9	240	1-1/8	28
	80	7/16	10	OVAL COMB		
	100	1/2	12	280	1-1/4	32
	120	9/16	15	310	1-1/2	38
	140	5/8	16	350	1-3/4	45
	160	3/4	20	400	2	50

WARRANTY POLICY

YOUR **CBM-650** HAS A WARRANTY OF ONE YEAR FROM DATE OF PURCHASE. IN THE EVENT OF A MANUFACTURER'S DEFECT, YOUR DISTRIBUTOR (AT OPTION) WILL REPAIR OR REPLACE IT. IMPORTANT: THIS WARRANTY DOES NOT COVER DAMAGES DUE TO IMPROPER USE OR MISS TREATMENT OF THE UNIT, INCLUDING ANY EXTRAORDINARY EVENT LEADING TO THE DAMAGE OF THE MACHINE, WHETHER IT IS REVERSIBLE OR NOT.

IF THE **CBM-650** IS NOT WORKING PROPERLY, FIRST FOLLOW THE CORRECTIVE ACTIONS ABOVE. IF THE PROBLEM PERSISTS, PLEASE CONTACT YOUR DEALER FOR FURTHER INSTRUCTIONS. PLEASE HAVE YOUR MACHINE'S SERIAL NUMBER AND THE PURCHASE DATE READY. IF THE MACHINE MUST BE RETURNED TO YOUR DISTRIBUTOR, IT IS YOUR RESPONSIBILITY TO PROPERLY PACK AND SHIP IT. AS ANY DAMAGES INCURRED DURING ITS TRANSPORTATION IS NOT COVERED BY OUR WARRANTY POLICY.